

# WOOD FITTINGS

## BRACKETS

Wood To Pipe Brackets - With Band	P. 57
Wood To Pipe Brackets - With Cap	P. 57
Wood To Pipe Corner Brackets - 90 Degree	P. 57
Wood To Pipe Corner Brackets - 180 Degree	P. 58

## DROP ROD GUIDES

Drop Rod Guides For Wood Gates	P. 56
--------------------------------	-------

## FLANGES

Floor Flange With Uprights	P. 56
----------------------------	-------

## HINGES

Wood Gate Strap Hinges	P. 55
Hinge Bolts For Wood - Lag Thread	P. 55
Block Wall Hinge	P. 55

## LATCHES

Flat Back Latches - Little Ear Butterfly	P. 56
--	-------

## ORNAMENTAL IRON BANDS

Ornamental Iron Bands - Heavy Steel U-Bands	P. 58
---	-------



# WOOD FITTINGS - GALVANIZED

Part No.	Size	Per Sack	Lbs Each	Wood Gate Strap Hinges
35181	6" x 1/2" x 1"	100	0.412	
35182	8" x 5/8" x 1-1/4"	100	0.800	
35183	14" x 5/8" x 2"	25	1.800	
Part No.	Size	Per Sack	Lbs Each	Hinge Bolts For Wood - Lag Thread
11362	1/2" x 4-1/2"	125	0.298	
11366	5/8" x 4-1/2"	125	0.485	
11367	5/8" x 6"	125	0.573	
Part No.	Size	Per Sack	Lbs Each	Block Wall Hinge 5/8" Pin - 3/16" GA. Steel
35201	5/8" PIN	100	0.900	

# WOOD GATE FITTINGS - GALVANIZED

<b>Flat Back Latch Little Ear Butterfly Self-Lifting - Self-Latching</b>	Part No.	Size	Per Sack	Lbs Each
	23215	To Pipe OD 1-5/16"	50	1.550
	23235	To Pipe OD 1-5/8"	50	1.400
	23234	To Pipe OD 1-7/8"	50	1.300
<b>Drop Rod Guide - For Wood Gates Or Flat Surfaces</b>	Part No.	Size	Per Sack	Lbs Each
	35161	FOR 1/2" RODS	250	0.160
<b>Floor Flange - With Uprights For 4" x 4" Wood Posts</b>	Part No.	Size	Per Sack	Lbs Each
	19111	6" x 6" SQ 1/4" THICK	10	3.850

# WOOD FITTINGS - GALVANIZED

Part No.	Size	Per Sack	Lbs Each	Pressed Steel Wood To Pipe Flat Brackets - With Steel Cap
35103	1-5/8"	100	0.420	
35104	1-7/8"	100	0.480	
35106	2-3/8"	100	0.570	
Part No.	Size	Per Sack	Lbs Each	Wood To Pipe Brackets With Heavy Steel Band 1" x 1/8" GA.
35123	1-5/8"	100	0.488	
35124	1-7/8"	100	0.504	
35126	2-3/8"	100	0.570	
35127	2-7/8"	100	0.613	
Part No.	Size	Per Sack	Lbs Each	Wood To Pipe Corner Brackets 90 Degree With Heavy Steel Band
35114	1-7/8"	100	0.620	
35116	2-3/8"	100	0.700	
35117	2-7/8"	100	0.782	

# WOOD FITTINGS

Galvanized Wood To Pipe Brackets 180 Degree With Heavy Steel Band (Good Neighbor Style)	Part No.	Size	Per Sack	Lbs Each
	35144	1-7/8"	100	0.630
	35146	2-3/8"	100	0.724
	35147	2-7/8"	100	0.810

# ORNAMENTAL IRON BANDS

Heavy Steel U-Bands Not Galvanized	Part No.	Size	Per Sack	Lbs Each
	40151	1" 11GA. x 1"	250	0.165
	40152	1-1/2" 11GA. x 1"	100	0.213
	40153	2" 3/16" x 1"	100	0.426

# HARDWARE & TOOLS

## BOLTS - GALVANIZED

Carriage Bolts	P. 59
U-Bolts	P. 59
Eye Bolts	P. 60
Hook Bolts	P. 60
Wire Stretching Bolts	P. 60
Machine Bolts	P. 61

## NUTS

Hex Nuts	P. 61
----------	-------

## TOOLS

Gate Making Tool	P. 62
Pliers	P. 62

## PIPE NOTCHER

Original F.T.F. Pipe Notcher	P. 63
------------------------------	-------

# BOLTS - GALVANIZED

Part No.	Size	Per Sack	Lbs Each
11302	5/16" OD x 1-1/4" L	2,000	0.039
11303	5/16" OD x 1-1/2" L	2,000	0.043
11304	5/16" OD x 1-3/4" L	1,000	0.047
11305	5/16" OD x 2" L	1,000	0.051
11306	5/16" OD x 2-1/4" L	1,000	0.055
11307	5/16" OD x 2-1/2" L	1,000	0.059
11311	3/8" OD x 1-1/4" L	1,000	0.061
11312	3/8" OD x 1-1/2" L	1,000	0.067
11313	3/8" OD x 2" L	1,000	0.078
11314	3/8" OD x 2-1/4" L	1,000	0.084
11315	3/8" OD x 2-1/2" L	1,000	0.090
11316	3/8" OD x 2-3/4" L	1,000	0.095
11317	3/8" OD x 3" L	1,000	0.101
11318	3/8" OD x 3-1/2" L	1,000	0.112
11319	3/8" OD x 4" L	1,000	0.124

## Hot-Dip Galvanized Carriage Bolts With Nuts



Part No.	Size	Per Sack	Lbs Each
11401	2" x 3-15/16"	125	0.463
11402	2-3/8" x 4-1/16"	125	0.507
11403	2-7/8" x 3-3/4"	100	0.520
11404	3-1/2" x 4-15/16"	100	0.650
11405	4" x 5-1/2"	100	0.680
11406	4-1/2" x 6-1/2"	50	0.772
11411	2" x 3-5/16"	100	0.395
11412	3" x 4-5/8"	100	0.550

## U-Bolts For Rolling Gate 1/2" Round Steel - With Nuts



Part No.	Size	Per Sack	Lbs Each
11421	6-5/8" x 8-3/4"	25	1.800
11422	8-5/8" x 11"	25	1.984

## U-Bolts - Industrial Size 5/8" Round Steel - With Nuts

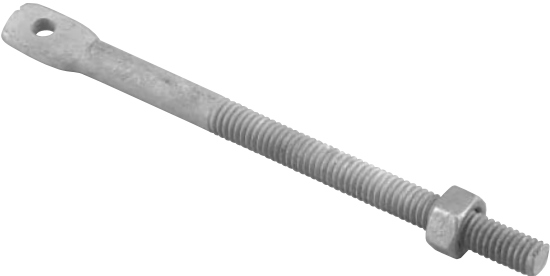

# BOLTS - GALVANIZED

Hook Bolts - With Nut	Part No.	Size	Per Sack	Lbs Each
	11381	1/4" OD x 5" L	500	0.077
	11382	5/16" OD x 6" L	500	0.154
	11383	3/8" OD x 6" L	250	0.194
Eye Bolts - 3/8" Eye - With Nut	Part No.	Size	Per Sack	Lbs Each
	11321	3/8" x 2-3/4"	250	0.155
	11322	3/8" x 4-1/2"	250	0.205
	11323	3/8" x 6"	50	0.245
Wire Stretching Bolt - With Nut	Part No.	Size	Per Sack	Lbs Each
	11435	5/16" OD x 5" L	500	0.106





# BOLTS - GALVANIZED

Part No.	Size	Per Sack	Lbs Each	Machine Bolts - With Nut
11391	3/8" OD x 3" L	500	0.127	
11392	1/2" OD x 3" L	300	0.191	
11393	1/2" OD x 3-1/2" L	300	0.222	
11394	5/8" OD x 4-1/2" L	100	0.500	
11397	5/8" OD x 6-1/2" L	75	0.558	

# NUTS

Part No.	Size	Per Sack	Lbs Each	Hex Nuts - Galvanized
24101	Finish 1/4"	200	0.010	
24102	Finish 5/16"	200	0.011	
24103	Finish 3/8"	200	0.012	
24121	Finish 1/2"	200	0.020	
24141	Finish 5/8"	200	0.030	

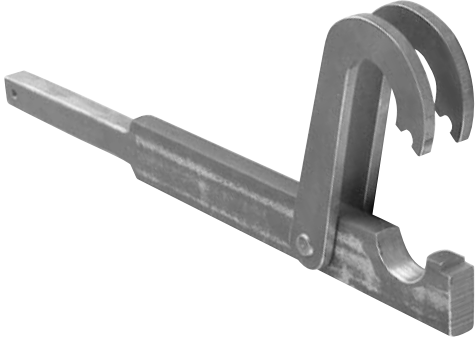
# TOOLS

Gate Making Tool Heavy Duty - 2-Way	Part No.	Size	Per Sack	Lbs Each
	37020	Two Way	1	4.25
		Used to Stretch Fabric		
Pliers - Fencer Industrial	Part No.	Size	Per Sack	Lbs Each
	02200	Three In One -10"	3	1.25
Pliers - Hog Ring	Part No.	Size	Per Sack	Lbs Each
	02300	Spring Type	4	0.76
	02400	B.O.E. Custom	4	0.870

# FTF PIPE NOTCHERS

**NOW YOU CAN NOTCH THE PIPE FOR YOUR GATE  
BEFORE WELDING FOR SMOOTHER STRONGER GATE!**

Provides smooth curved notch to insure a strong weld where welded joints are required.

- Includes three sets of dies for cutting pipe  
O.D. 1 5/16" - 1 5/8" - 1 7/8"
- Hand operated with smooth steady cam action
- Dies are easily changed
- Easy to clean

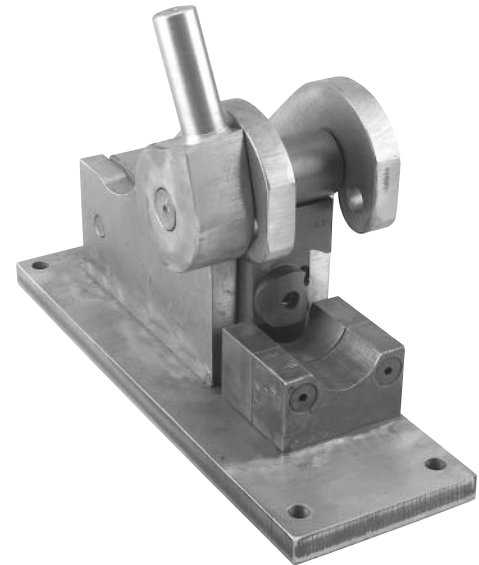

Description	Part No.	Size	Weight (Lbs Each)
<b>PIPE NOTCHER ASSEMBLY (Includes three sets of punches &amp; dies)</b>	<b>37001</b>	<b>1-5/16" THRU 1-7/8"</b>	78.000
<b>PARTS ONLY:</b>			
PUNCH 1-5/16"	<b>89001</b>	<b>1-5/16"</b>	1.600
PUNCH 1-5/8"	<b>89002</b>	<b>1-5/8"</b>	1.600
PUNCH 1-7/8"	<b>89003</b>	<b>1-7/8"</b>	1.600
PUNCH 2-3/8"	<b>89004</b>	<b>2-3/8"</b>	1.600
DIE 1-5/16"	<b>89011</b>	<b>1-5/16"</b>	2.500
DIE 1-5/8"	<b>89012</b>	<b>1-5/8"</b>	2.500
DIE 1-7/8"	<b>89013</b>	<b>1-7/8"</b>	2.500
DIE 2-3/8"	<b>89014</b>	<b>2-3/8"</b>	2.500
BACK UP - BLOCK 1-5/16"	<b>89021</b>	<b>1-5/16"</b>	3.160
BACK UP - BLOCK 1-5/8"	<b>89022</b>	<b>1-5/8"</b>	3.160
BACK UP - BLOCK 1-7/8"	<b>89023</b>	<b>1-7/8"</b>	3.160
BACK UP - BLOCK 2-3/8"	<b>89024</b>	<b>2-3/8"</b>	3.160
CAM - 3/4"	<b>89030</b>		1.660
CAM - 1"	<b>89031</b>		1.820
CAM AND HANDLE - 1"	<b>89035</b>		5.250
CAM AND HANDLE - 3/4"	<b>89036</b>		5.250
ROCKER ARM	<b>89041</b>		8.500
RETURN SPRING	<b>30150</b>		0.015
SOCKET FLAT HEAD PUNCH	<b>11472</b>		0.015
MOUNTING SCREWS			
SOCKET FLAT HEAD PIPE STOP	<b>11473</b>		0.015